

Microcontroller based Interferential Current Therapy for Pain Relief

ShwetaAmit Borkar¹
¹(EXTC Department, RMCET Ambav, India)

Abstract: In this paper the idea of Interferential current therapy is discussed. Interferential current therapy is an effective therapy option used by many physiotherapy clinics to relieve pain and accelerate the self-healing process, getting your body back to a healthy, pain free state. This therapy uses two medium frequency currents, passed through the tissues simultaneously, where they are set up so that their paths cross and they interfere with each other. This interaction gives rise to an interference current (beat frequency) which has the characteristics of low frequency stimulation. This low frequency helps pain relief.

Keywords: Electrodes, IFC, IFT.

I. Introduction

The basic principle of **Interferential Therapy** (IFT) is to utilise the significant physiological effects of low frequency (<250pps) electrical stimulation of nerves without the associated painful and somewhat unpleasant side effects sometimes associated with low frequency stimulation.[1]

Generally low frequency with sufficient intensity is used for muscle stimulation. But the main problem associated with the application of low frequency current to patients is the very high skin impedance, because $Z=1/2\pi fC$, where f is frequency. Using high frequency current will reduce the impedance and hence reduce the discomfort that is caused by low frequency currents. [2] At the same time, Interferential current (IFC) produces low frequency effects in deeper tissues of the body resulting in the therapeutic effect of the low frequency current therapy. It works on 'change in the local tissue environment' by creating local increase in deep seated tissue temperature (just like we do local fermentation with hot water on body surface) which leads to pain relief.

II. Working Principle

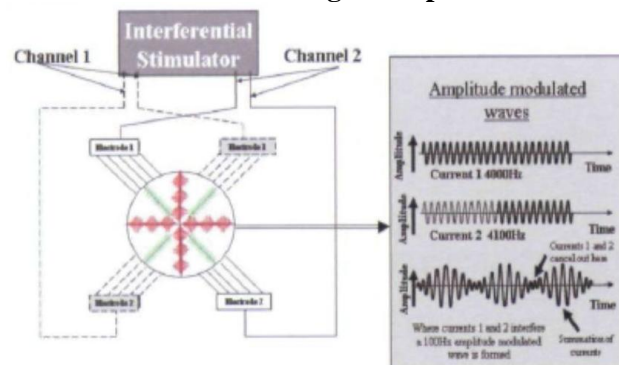

Fig.1: Generation of Amplitude modulated interference wave

To create this interferential current two carrier signals of different frequencies are used which interfere to produce a low frequency. These two signals produce an interferential current signal with amplitude modulated frequency of $f=f_2-f_1$ as shown in fig. This is called Beat frequency. The interference takes place inside the body. Therefore carrier waves achieve greater depth of penetration, due to their high frequencies that short circuit the skin capacitance, and produce interferential current while the resulting beat frequency signal causes the desired therapy.

If for example, one current was at 4000Hz and its companion current at 3900Hz, the resultant beat frequency would be at 100Hz, carried on medium frequency 3950Hz amplitude modulated current. By careful manipulation of the input currents it is possible to achieve any beat frequency that you might wish to use clinically. Modern machines usually offer frequencies of 1-150Hz, though some offer a choice of up to 250Hz or more. To a greater extent, the therapist does not have to concern themselves with the input frequencies, but simply with the appropriate beat frequency which is selected directly from the machine. The magnitude of the low frequency interference current is (in theory) approximately equivalent to the sum of the input amplitudes.

III. Microcontroller Based IFT

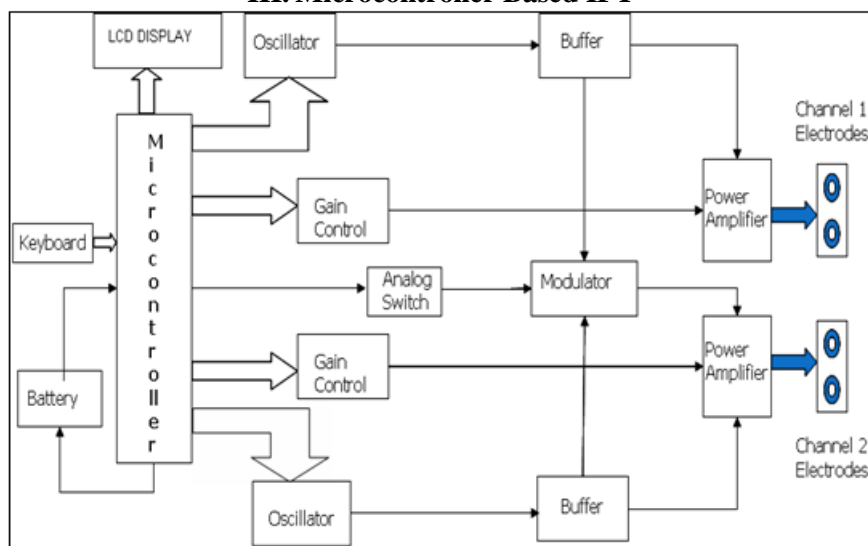

Fig.2: Block diagram of proposed microcontroller IFCT

Block diagram of microcontroller based IFT is as shown in fig. 2. This IFT is battery operated. Chargeable battery is connected to microcontroller. The battery voltage is read by controller, if it is less than 12.5V charging of battery starts & if the battery voltage becomes greater than 14V then charging of battery stops. With the help of 4 X 4 keyboard matrix different modes of operations of IFT is selected. This IFT is operated in 2 modes of operations. 1) IFT using two electrodes (one channel) 2) IFT using 4 electrodes (two channels). These two modes are controlled by analog switch. When it is on first mode is selected & when it is off mode 2 is selected.

IV. Four Electrode Mode

In this mode of operation Oscillator of channel1 generates 4KHz or 2KHz frequency signal. The selection of frequency is also done by microcontroller. Oscillator of channel2 generates either (4KHz + Beat frequency) or (2KHz + Beat frequency) depending on frequency selection. Output of both oscillators are fed to corresponding buffers and then to respective power amplifiers. Gain of power amplifier is controlled by microcontroller. Thus amplified frequency signals 4KHz or 2KHz & (4KHz + Beat frequency) or (2KHz + Beat frequency) will appear across channel 1 electrodes & channel 2 electrodes respectively. When four electrodes are applied to the body, the optimum interference effect occurs when they are arranged cross diagonally as shown in the fig. 4 the currents Maximum nerve excitation occurs endogenously in the region of the tissue where the currents from the two circuits cross. Around the geometric center between the four electrode, the total current is the sum of from each pair of electrodes. Interferential Therapy delivers a continuous stimulation deep into the affected tissue.

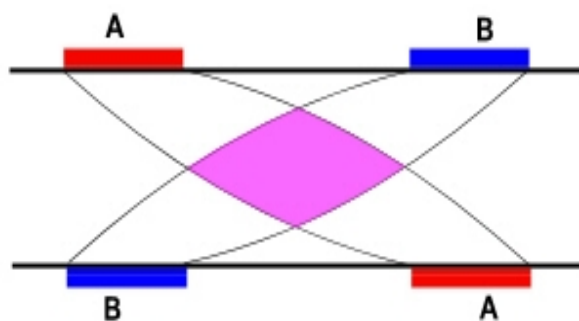

Fig.3: Interferential current by using 2 set of electrodes A and B

V. Conclusion

There are many clinical applications for which IFCT appears to be used. It leads to following advantages like it increases local temperature which results in soothing effect due to large nerve fiber stimulation, increases blood flow with fresh blood which improves the nutrition status, blood vessel dilatation

reduces local swelling and oedema, increased circulation washes away 'P' substrate and other harmful material and tissue repair its healing is enhanced due to high metabolism.[3][5]

References

Journal Papers:

- [1]. Warden, SJ "A new direction for ultrasound therapy in sports medicine", *Sports Med.*, 33(2), 95-1, 2003.
- [2]. Wilkin LD, Merrick MA, Kirby TE, Devor ST. "Influence of therapeutic ultrasound on skeletal muscle regeneration following blunt contusion", *Int J Sports Med.* 2004 Jan; 25(1):73-7
- [3]. Stuart J. Warden, BPhysio (Hons), PhD, Keith G. Avin, MS, Erin M. Beck, PTA, Marie E. DeWolf, ATC, Molly A. Hagemeyer, and Kristin M. Martin "Low-Intensity Pulsed Ultrasound Accelerates and a Nonsteroidal Anti-inflammatory Drug Delays Knee Ligament Healing", *The American Journal of Sports Medicine*, Vol. 34, No. 7, 2006

Books:

- [4]. *Clayton's Electrotherapy*; By Angela Forster & Nigel Palastanga
- [5]. *Clinical Electrotherapy*; By Roger M. Nelson & Dean P. Currier